

THIS DWG. IS THE PROPERTY AND COPYRIGHT OF DEL EQUIPMENT LIMITED AND MAY NOT BE REPRODUCED BY ANY MEANS UNLESS WITH THE EXPRESSED PERMISSION OF DEL

REV	DESCRIPTION	DATE
REVISION HISTORY		
AIR VALVE, INSTALLATION		SHEET:
1295-99-01		1 OF 2
GEN. TOL:	GENERAL Ra:	CHKD:
.XXX ± 1/16	N/A	μIN
.XX ± 1/8	GEN. CONCENTRICITY:	DRWN: O.S. DEC. 01/17
X ± .1/2	N/A	TIR
	CORNERS/EDGES:	REVD:
	N/A	
MATL: Z3	MAKE FROM: SEE ABOVE	REV: .



TOUGHNESS YOU CAN TRUST

WEIGHT: 0.00 lbm VOLUME: 0.00 in³

UNITS: INCHES

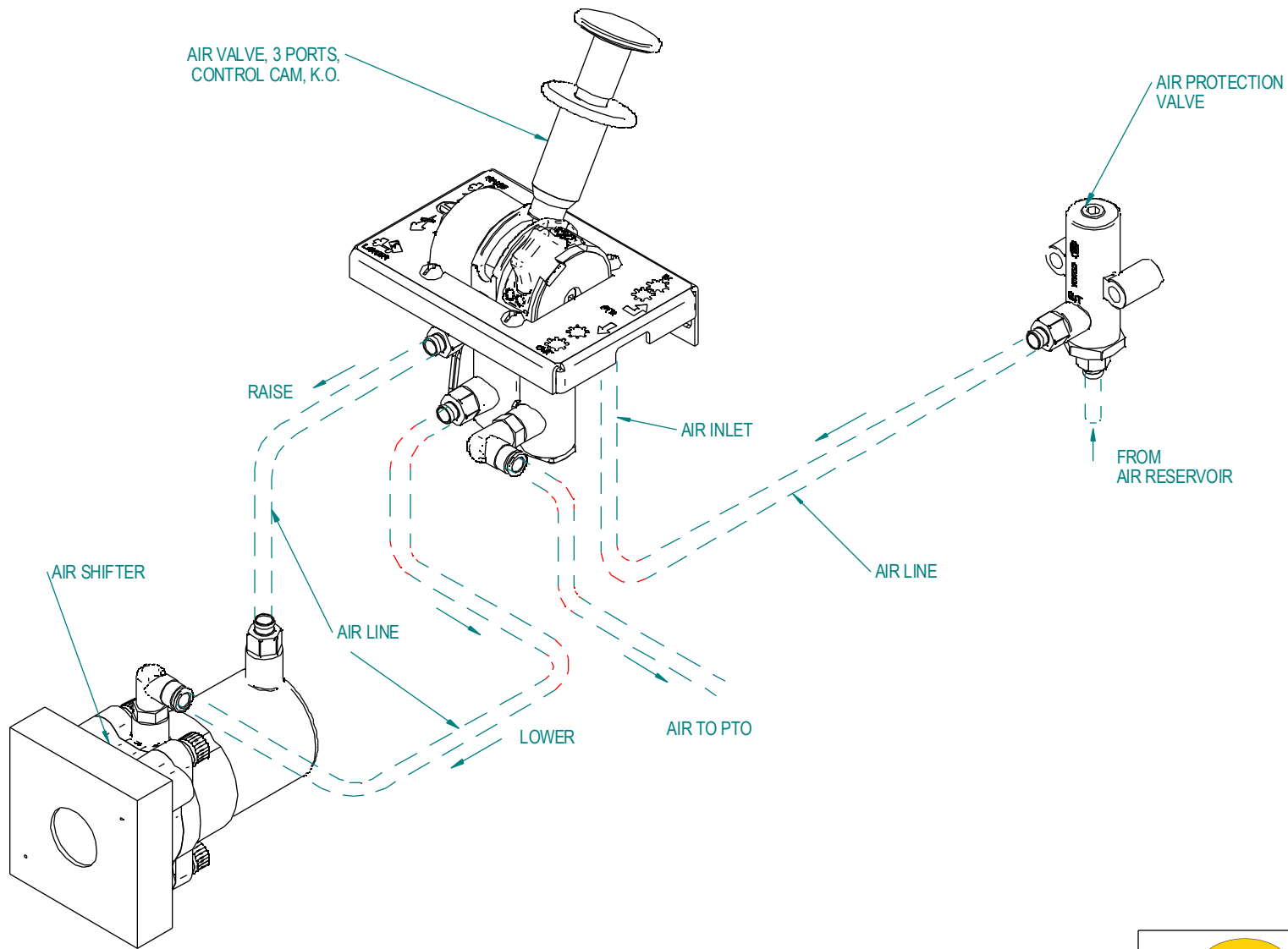

THIS DWG. IS THE PROPERTY AND COPYRIGHT OF DEL EQUIPMENT LIMITED AND MAY NOT BE REPRODUCED BY ANY MEANS UNLESS WITH THE EXPRESSED PERMISSION OF DEL

REV	DESCRIPTION	DATE
REVISION HISTORY		
AIR VALVE, INSTALLATION		SHEET:
1295-99-01		2 OF 2
GEN. TOL:	GENERAL Ra:	CHKD:
.XXX ± 1/16	N/A	μIN
.XX ± 1/8	GEN. CONCENTRICITY:	DRWN: O.S. DEC. 01/17
X + .1/2	N/A	TIR
	CORNERS/EDGES:	REVD:
	N/A	
MATL: Z3	MAKE FROM: SEE ABOVE	REV: .



TOUGHNESS YOU CAN TRUST

WEIGHT: 0.00 lbm

VOLUME: 0.00 in³

UNITS: INCHES