

DEL HYDRAULICS PNEUMATIC CONTROLS

CONTROL SOLUTIONS FOR MOBILE APPLICATIONS

24th Edition



**DEL Products are proudly manufactured in
Buffalo, New York!**

**DEL Hydraulics, INC.
50 Stradtman Street Buffalo, NY 14206**

DEL PUTS YOU IN CONTROL

TABLE OF CONTENTS

PAGE	CONTENTS
2	<u>1201 VALVE, BRACKET, & PTO AIR KIT</u>
3	<u>1202, 2202 & 1203 VALVES</u>
4	<u>1202 & 1203 ACCESSORIES/REPAIR KITS</u>
5	<u>1295 VALVE</u>
6	<u>1295 REPAIR KITS & 1204 VALVE</u>
7	<u>1205 & 1208 VALVES</u>
8	<u>1213 & 1214 VALVES, 1214 ACCESSORIES</u>
9	<u>1221 SINGLE VALVES</u>
10	<u>1221 BANKED VALVES & ACCESSORIES</u>
11	<u>1224 VALVES & ACCESSORIES</u>
12	<u>1261 & 1264 VALVES</u>
13	<u>DECALS</u>
14	<u>1229 VALVES</u>
15	<u>1229 ACCESSORIES & REPAIR KITS</u>
16	<u>JOYSTICK GUIDE</u>
17	<u>JOYSTICK PART NUMBERS</u>
18	<u>JOYSTICK REPAIR KITS</u>
19	<u>DUMP PUMP ACTUATORS</u>
20	<u>HYDRAULIC VALVE ACTUATORS</u>
21	<u>CONTROL CONSOLES</u>
22	<u>CONTROL PEDESTALS</u>
23	<u>SYSTEM ACCESSORIES</u>
24	<u>PRE-ASSEMBLED CONTROL PACKAGES & CUSTOM CONSOLES</u>
25	<u>SAFETY SYSTEMS</u>
26	<u>DEL ACK SYSTEM</u>

DEL PUTS YOU IN CONTROL

WHY CHOOSE DEL?

CUSTOMER SERVICE

Our customer service team has years of knowledge to help you with any of our products. At DEL Hydraulics we are dedicated to helping our customers with any request.



VALUE

All of our products are manufactured in Buffalo, NY

DEL products are made to last using high quality materials

Most of our products can be rebuilt or repaired in the field saving you time and money

Quick and easy installation

CUSTOM SPECIFICATIONS

Since 1945, DEL Hydraulics has been designing, engineering, and manufacturing evolutionary air controls for a wide variety of demands. No matter the application our team will find a solution!



AVAILABILITY

Standard orders ship within 1-2 business days

Short lead times so you can get your system up and running with little downtime

Parts can be expedited if needed

DEL Hydraulics helps each customer until the job is done and beyond!

DEL PUTS YOU IN CONTROL

SINGLE AXIS CONTROLS



Stackable FEATHERING Valves utilizes one common inlet port and exhaust port with one standard bolt length. Various bankable applications such as wet line kits, dump pump controls, municipal snowplow vehicles, dump bodies, refuse vehicles and more. Offset handles allow for a clean installation that results in labor cost savings.

- 0-120 psi feathering (proportional/metering) control
- Ability to stack the valves into bankable configurations
- Optimal PSI: between 85 and 120

OPTIONS:

- Back-Lit Knobs for all driving conditions, especially at night
- Neutral Detent
- 3-Position Detent: Raise / Lower / Neutral
- Detent Clip
- Spacer to accept various straight handle configurations
- Decals to clearly show function of valve

DUAL AXIS CONTROLS



FEATHERING Joysticks take advantage of a compact assembly allowing single lever control of dual axis valves. Capable of 360° articulation. Various applications include front end loaders, roll-offs and municipal snowplow trucks.

OPTIONS:

- Heavy duty return springs
- Various mounting plates to fit your application
- Push insert cartridge (PIC) fittings to make installation easy
- Electric control grips with hollow handles for hidden wire routing

DUMP PUMP ACTUATORS

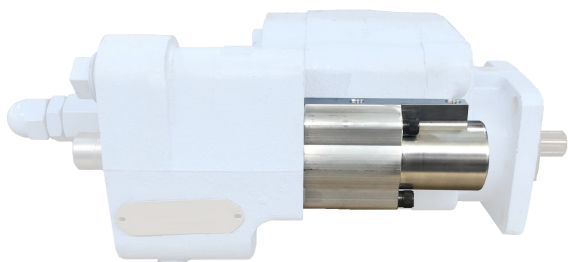

Direct-mount **Dump Pump Actuators** for various hydraulic dump pumps. Allows proportional control for lowering dump bodies and dump trailers utilizing DEL single axis or dual axis air controls.

HYDRAULIC VALVE ACTUATORS

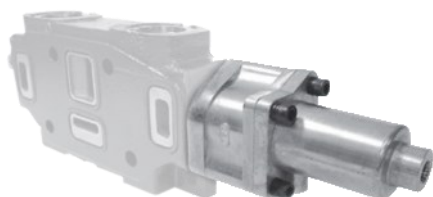

DEL's **Air Shift Cylinders** are designed to control the shifting of hydraulic valves. Directly mounts to the end of the hydraulic spool to allow full proportional/feathering control of various applications.

Features:

- Balanced areas for *True Proportional Control*
- Simple installation with no outside moving parts
- Die cast Zinc alloy or Aluminum body to deter corrosion
- Non-binding design
- Pre-assembled for quick installation
- Compact design

PNEUMATIC CONTROL VALVES

Valve Applications

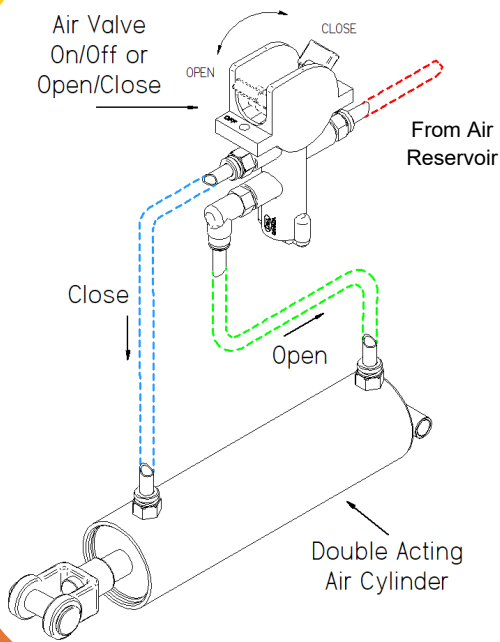

1201 VALVE

2 POSITION, A/B OR ON-OFF LEVER
D14-1201-99-05

2 POSITION, A/B OR ON/OFF LEVER
W/MICROSWITCH D14-1201-99-06

2 POSITION, A/B OR ON/OFF
LOCKING TRACK W/MICROSWITCH
& CHELSEA BRACKET W/ LED
D14-1201-99-13

2 POSITION, A/B OR ON/OFF
LOCKING TRACK W/MICROSWITCH
& DEL 1221 BRACKET W/ LED
D14-1201-99-14

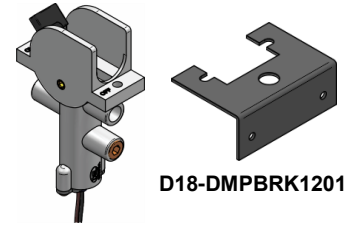

D14-1201-99-06

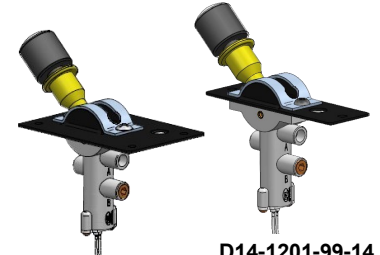

D14-1201-99-13

D14-1201-99-14

AIR PTO LEVER KIT

1201 PTO AIR KIT

INCLUDES: 1201-99-06, PRESSURE PROTECTION VALVE, MOUNTING BRACKET, FLASHING LED, 1/4"

SLIM CONSOLE AND VALVE ASSEMBLIES

DESIGNED TO BE MOUNTED BETWEEN DRIVER DOOR & SEAT

NEEDS LESS THAN 3.75" OF SPACE



AVAILABLE AS A KIT OR À LA CARTE

See additional custom consoles and pre-made assemblies on [Page 24](#)

Call us today (716) 853-7996 to discuss your specific need!

BACK TO T.O.C.

PNEUMATIC CONTROL VALVES



1202 VALVE

Main functions include **Raise, Hold, and Lower** the hoist of dump trucks and trailers.

The **1202 valve** can also control the movement of pneumatic shift cylinders fitted to various hydraulic work sections or dump pumps.

HOIST CONTROL, RAISE, NEUTRAL, LOWER **D14-1202-99-01**

MINI HOIST CONTROL, RAISE, NEUTRAL, LOWER - 1/4" PTC FITTINGS INSTALLED **D14-2202-99-01**

HOIST CONTROL, RAISE, LOWER W/ WILLIAMS PLATE **D14-1202-99-20**

HOIST CONTROL, SPRING RETURN FROM RAISE **D14-1231-99-01**

HOIST CONTROL, SPRING RETURN FROM RAISE/LOWER **D14-1232-99-01**

Valve Applications

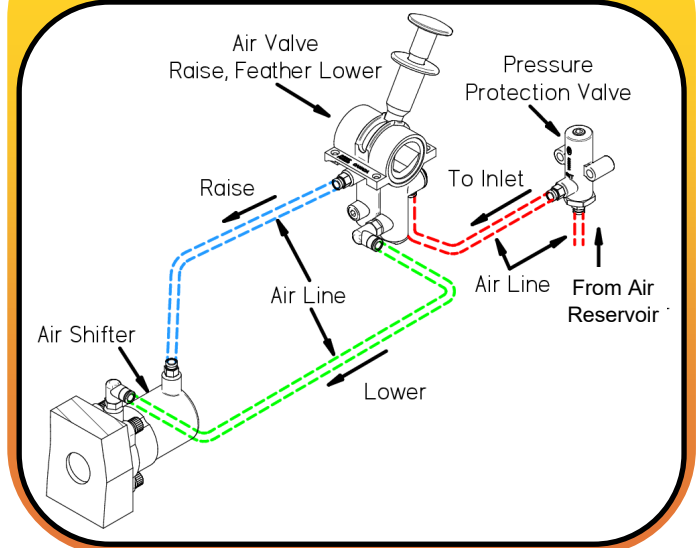

2202 VALVE

Same functions as the 1202 valve but half the width!

The D14-2202-99-01 includes 1/4" push to connect fittings

1203 VALVE



DUAL VALVES

3 POSITION:
RAISE
NEUTRAL - FEATHERING
LOWER

2 POSITION:
ON-OFF

OPTIONAL: PTO disengagement when the dump body is **FULLY LOWERED**.

HOIST PTO CONTROL **D14-1203-99-01**

HOIST PTO CONTROL PTO DISENGAGEMENT **D14-1203-99-02**

Valve Applications

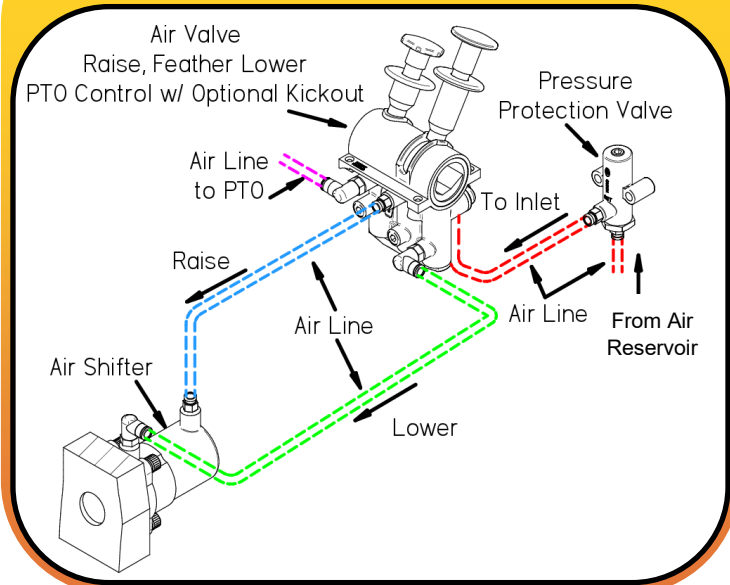

PNEUMATIC CONTROL VALVES

1202 & 1203 ACCESSORIES

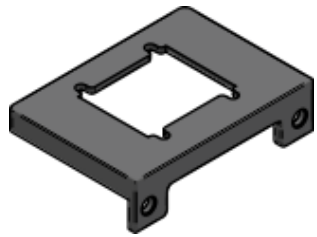

1202 BRACKET

1202 DASH MOUNTED BRACKET
D18-DMPBRK1202

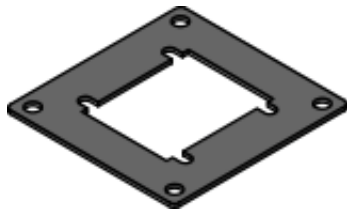

1202 WM BRACKET

1202 WILLIAMS BRACKET
D18-1202-99-20

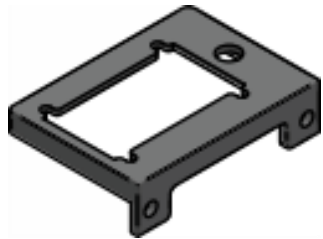

1203 BRACKET

1203 DASH MOUNTED BRACKET
D18-DMPBRK1203

Our brackets are made to fit our DEL air control valves for easy installation for any application

See console control [page 21](#)

1202 & 1203 REPAIR KITS

Minor Repair Kits

- Includes O-rings, springs, and screws
- **DOES NOT** include pistons

Major Repair Kits

- Includes O-rings, springs, screws, pistons

Screws NOT pictured

1202 Minor Repair Kit D02-1202S001M

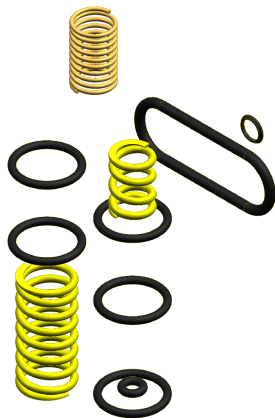

1202 Major Repair Kit D02-1202S002M



1203 Minor Repair Kit D02-1203S001M



1203 Major Repair Kit D02-1203S002M

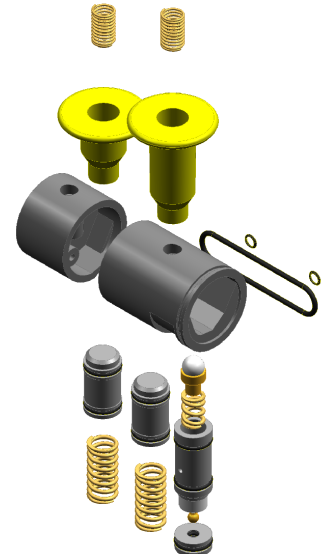

PNEUMATIC CONTROL VALVES

1295 VALVE

Valve Applications

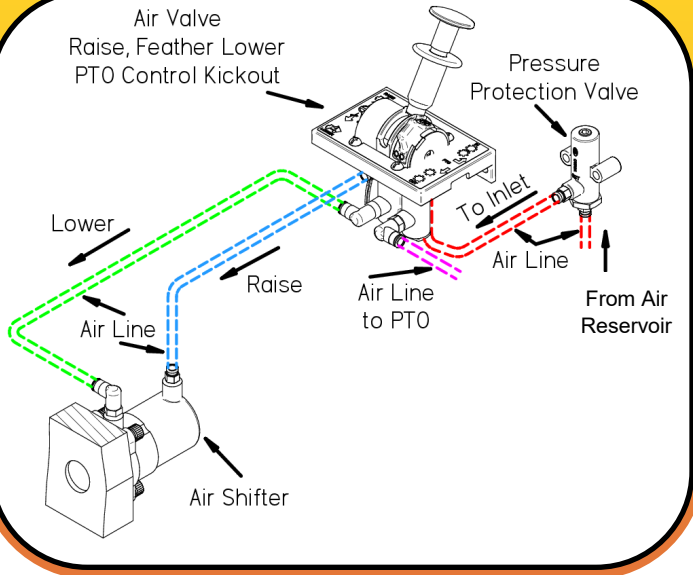

PTO HOIST AIR CONTROL

D14-1295-99-01

- Similar to our **D14-1203-99-02** but with a smaller footprint for easier installation into tight spaces
- Automatic disengagement of the PTO when the **red** lever is moved to the **FULLY LOWER** position
- Standard 1/8" NPT ports with 1/4" push to connect fittings (PTC) installed
- Pre-mounted in bracket that can be used in our precisely designed consoles

See console control [page 21](#)

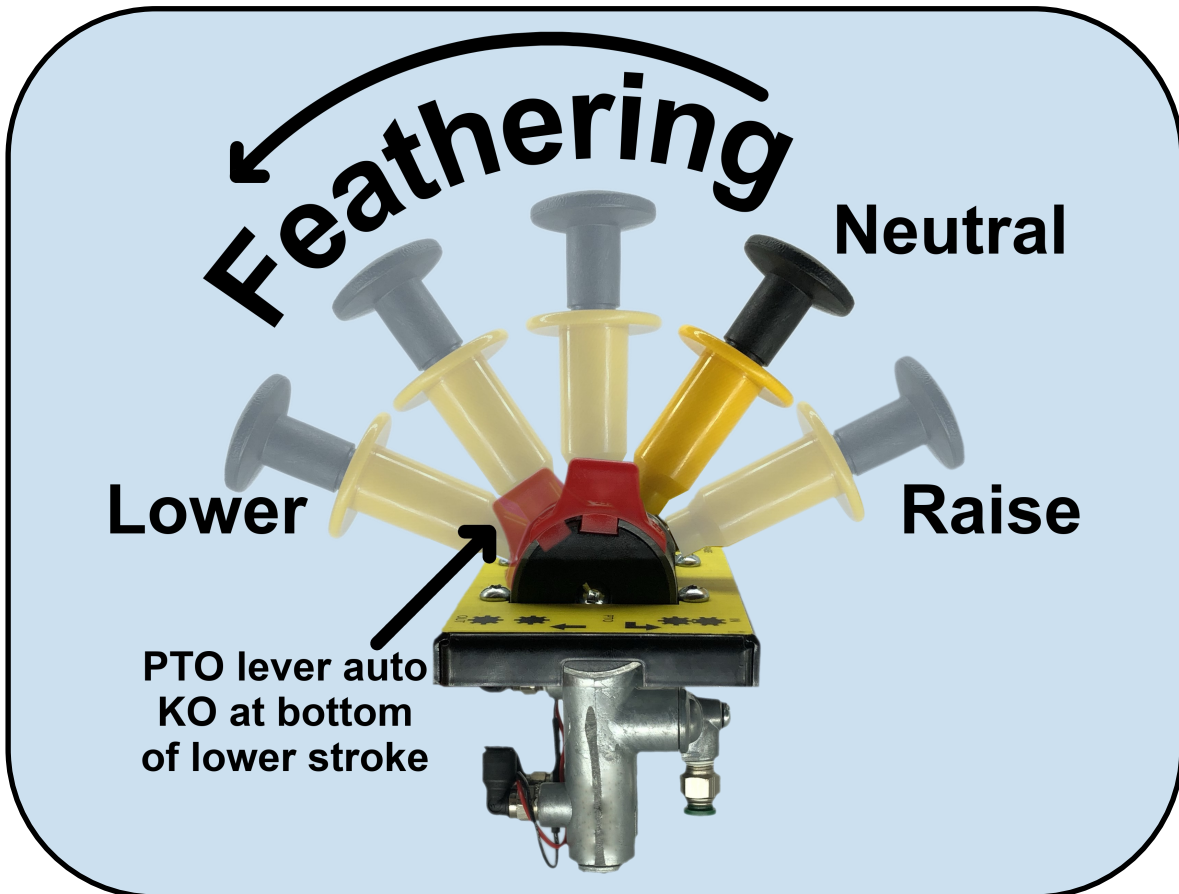

PNEUMATIC CONTROL VALVES



1205 VALVE

2 POSITION, ON/OFF VALVE WITH PIN LOCK

D14-1205-99-01



1208 VALVE

2 POSITION, LOCK OUT PTO
DISENGAGEMENT

D14-1208-99-01

1208 IN ACTION

PRESS PIN INWARD AND
DEPRESS BLACK KNOB
TO ENGAGE AIRFLOW
DOWNLINE

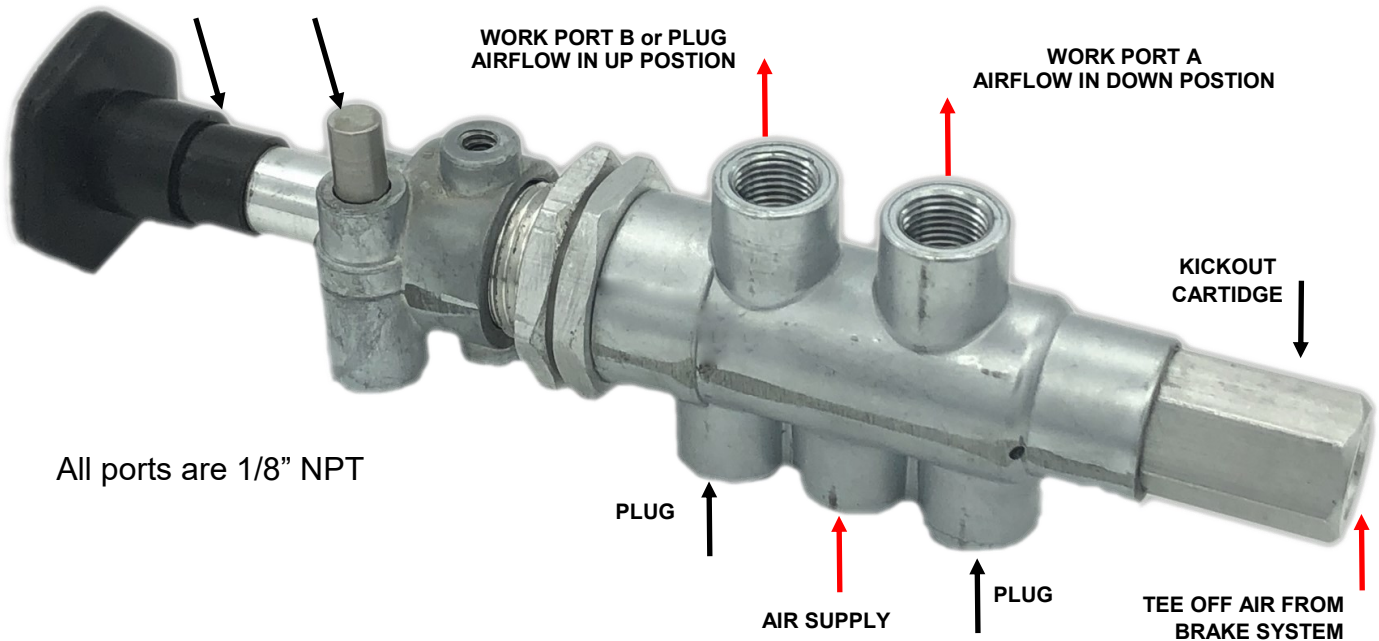

Use the **PTO SAVER** function designed by **DEL Hydraulics** to automatically disengage the PTO when spring parking brakes are released.

In addition to the **PTO SAVER**, use the spring parking brake release action to kick out other air controlled functions to create custom air control solutions.

PNEUMATIC CONTROL VALVES

1213 VALVE

KNOCK IN LIMIT VALVE / BODY UP INDICATOR
D14-1213-99-01

- Prevents air flow from supplying controls unless pin is depressed
- Stop unwanted control usage in certain setups
- Connect pressure sensor to output to switch electrical circuits - *Ex: Body up indicator*

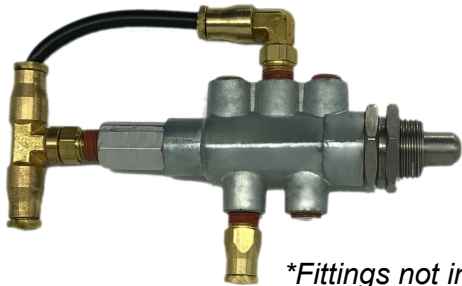

**Fittings not included*

1214 VALVE

DUMP ANGLE LIMIT VALVE
D14-1214-99-01

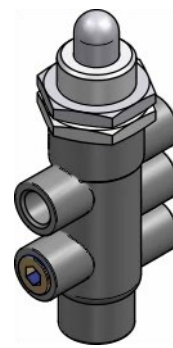

- Limits the stroke of the hydraulic cylinder
- **NO MORE** limit cables
- Stops the hydraulic cylinder at the end of the stroke
- *See below for optional adjustable bracket*

Valve Applications

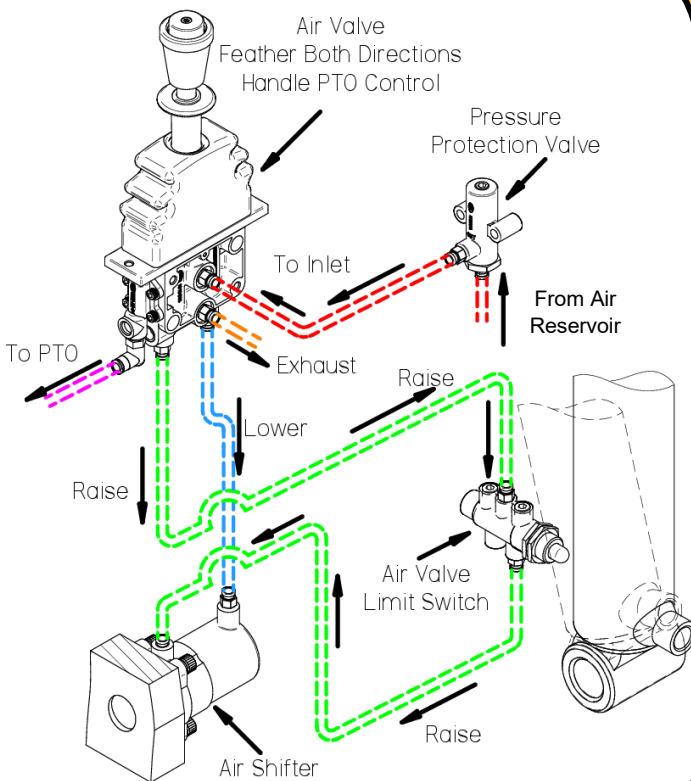

1214 BRACKET

1214 ADJUSTABLE BRACKET
D18-DMPBRK1214

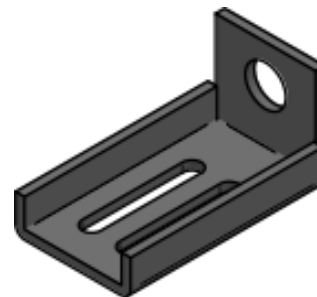

Bracket ONLY

1214 VALVE & BRACKET KIT

1214 VALVE WITH BRACKET KIT
DAV1214K

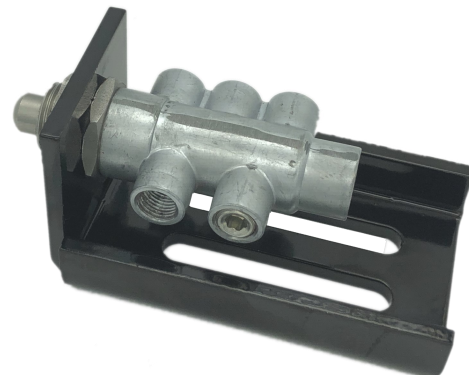

PNEUMATIC CONTROL VALVES

1221 VALVES

Stackable feathering valves using one common inlet and exhaust port with one standard bolt length. Provides various bankable applications such as **wet line kits, dump pump controls, municipal snowplow vehicles, dump bodies, refuse vehicles and more.**

FEATURES:

- 0-120 PSI proportional control
- Offset handles allow for clean installation that reduces labor cost
- All 1221 valves **feather** in both directions

OPTIONS:

- Valve spacer to accept various straight-handle configurations
- Decal to clearly show the function of each valve
 - See [page 13](#) for decal options
- Detent clip kit which can hold in the upper, lower, or both positions

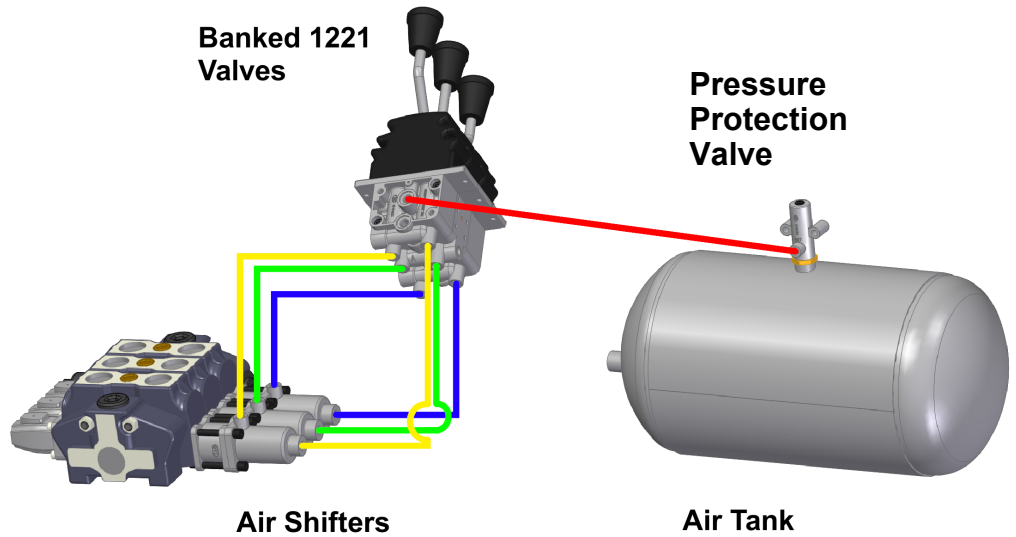

1221 SINGLE VALVES

STRAIGHT HANDLE VALVE (ST)	D14-1221-99-01
QUARTER BEND HANDLE VALVE (QB)	D14-1221-99-07
SHORT BEND HANDLE VALVE (SB)	D14-1221-99-02
LONG BEND HANDLE VALVE (LB)	D14-1221-99-03

1221 SPECIALTY VALVES

STRAIGHT 3" HANDLE VALVE	D14-1221-99-10
STRAIGHT HANDLE, SINGLE DETENT VALVE*	D14-1222-99-01
STRAIGHT HANDLE, DOUBLE DETENT VALVE*	D14-1223-99-01

*Detent also available for offset handles
EX: D14-1222-99-03 for LB with single detent

1221 HANDLE EXAMPLES

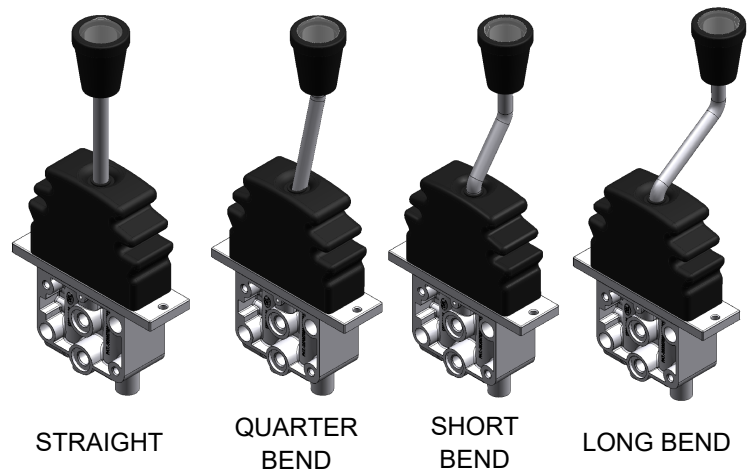

Please call our office at 716-853-7996
for custom valve applications

PNEUMATIC CONTROL VALVES

1221 BANKED VALVES

2-BANK AIR CONTROL VALVE SB X SB	D14-1221-2B-01
3-BANK AIR CONTROL VALVE SB X ST X SB	D14-1221-3B-01
4-BANK AIR CONTROL VALVE LB X SB X SB X LB	D14-1221-4B-01
5-BANK AIR CONTROL VALVE LB X SB X ST X SB X LB	D14-1221-5B-01
6-BANK AIR CONTROL VALVE LB X SB X QB X QB X SB X LB	D14-1221-6B-01
7-BANK AIR CONTROL VALVE LB X SB X QB X ST X QB X SB X LB	D14-1221-7B-01

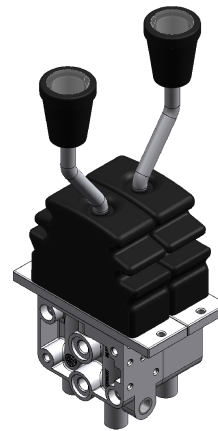

2 Bank Assembly

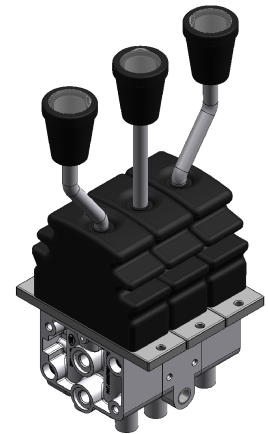

3 Bank Assembly

1221 ACCESSORIES

1221 REPAIR KITS

MINOR REPAIR KIT	D02-DAV1221MNRE
MAJOR REPAIR KIT WITH ST HANDLE	D02-DAV1221MJRE
MAJOR REPAIR KIT WITH QB HANDLE	D02-DAV1221MJ-07
MAJOR REPAIR KIT WITH SB HANDLE	D02-DAV1221MJ-02
MAJOR REPAIR KIT WITH LB HANDLE	D02-DAV1221MJ-03

1221 EXTRAS

BANKING ASSEMBLY ORING*	D02-DAV1221ORING
BANKING ASSEMBLY SCREW*	D03-DAV1221SCREW
RUBBER BOOT	D02-DAV1221RBT
DETENT CLIP KIT	D24-DETENTCLIPS
SPACER MANIFOLD BLOCK - BANKABLE	D24-DAV1221SPCRS

*To make custom valve assemblies, use 4 orings and 2 screws for each extra valve
 Examples: 3 valves to be banked = 8 Banking Orings, 4 Banking Screws
 4 valves to be banked = 12 Banking Orings, 6 Banking Screws

1221 UPPER HANDLES

UPPER HANDLE ASSEMBLY - ST HANDLE	D24-DAV1221UH
UPPER HANDLE ASSEMBLY - QB HANDLE	D24-DAV1221UH-07
UPPER HANDLE ASSEMBLY - SB HANDLE	D24-DAV1221UH-02
UPPER HANDLE ASSEMBLY - LB HANDLE	D24-DAV1221UH-03

D24-DAV1221UH



D24-DAV1221SPCRS

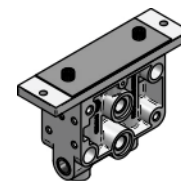

D24-DETENTCLIPS

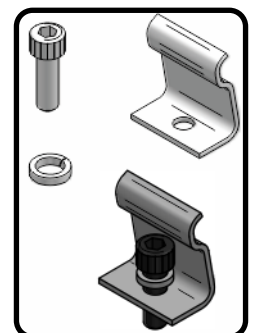

Supplied as kit

PNEUMATIC CONTROL VALVES

1224 VALVES

Stackable feathering valves using one common inlet and exhaust port with one standard bolt length similar to our **1221** valves. Mainly used for the **raising and lowering of the hoist on refuse vehicles, municipal snowplow vehicles, dump bodies, and more.**

FEATURES:

- 0-120 PSI proportional control
- Equipped with a locking handle to avoid accidental movement of the valve
- All 1224 valves **feather** in both directions

OPTIONS:

- Valve spacer to accept various straight-handle configurations
 - See [page 10](#) for valve spacer
- Decal to clearly show the function of each valve
 - See [page 13](#) for decal options
- Steel track that can hold in the neutral, lower, upper, or all 3 positions

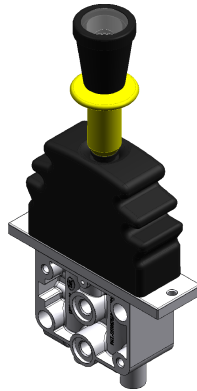

VALVE, LOCK IN NEUTRAL	D14-1224-99-03
VALVE, LOCKS IN 2 POSITIONS	D14-1224-99-04
VALVE, LOCKS IN 3 POSITIONS	D14-1224-99-05
DUAL LOCK IN NEUTRAL ASSEMBLY	D14-1224-1224

1224 ACCESSORIES

1224 UPPER HANDLES

D14-1224-99-03 UPPER HANDLE ASSEMBLY	D24-DAV1224UH-03
D14-1224-99-04 UPPER HANDLE ASSEMBLY	D24-DAV1224UH-04
D14-1224-99-05 UPPER HANDLE ASSEMBLY	D24-DAV1224UH-05

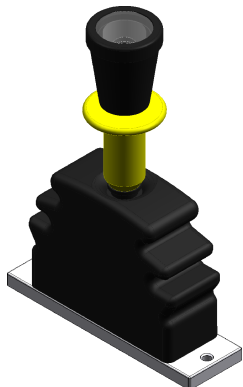

Our 1224 upper handles are interchangeable. Just switch the handles as the application changes.

1224 STEEL TRACKS

Used in D14-1224-99-03
Locks in the neutral position
D24-1264-84-21

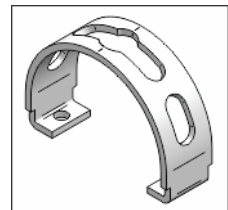

Used in D14-1224-99-04
Locks in 2 positions
D24-1264-84-22

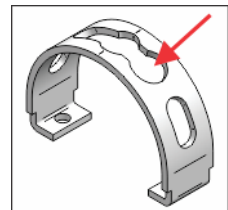

Used in D14-1224-99-05
Locks in 3 positions
D24-1264-84-23

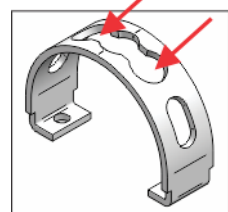

PNEUMATIC CONTROL VALVES

AIR CONTROLS with BACK-LIT KNOBS



1261 SINGLE VALVES

STRAIGHT HANDLE LIT KNOB VALVE (ST)	D14-1261-99-01
SHORT BEND HANDLE LIT KNOB VALVE (SB)	D14-1261-99-02
LONG BEND HANDLE LIT KNOB VALVE (LB)	D14-1261-99-03

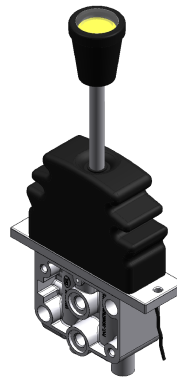

STRAIGHT



SHORT BEND

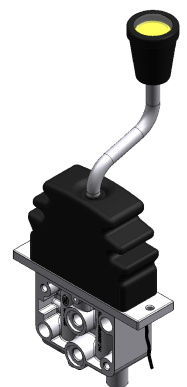

LONG BEND

1261 BANKED VALVES

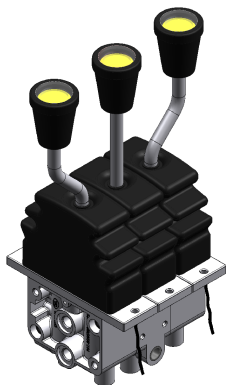

2-BANK VALVE, LIT KNOBS SB X SB	D14-1261-2B-01
3-BANK VALVE, LIT KNOBS SB X ST X SB	D14-1261-3B-01
4-BANK VALVE, LIT KNOBS LB X SB X SB X LB	D14-1261-4B-01
5-BANK VALVE, LIT KNOBS LB X SB X ST X SB X LB	D14-1261-5B-01

- Minimal current draw (1.18mA at 12 volt D.C.) LED lit knobs clearly shows the function of each valve no matter what the driving conditions are.
- See [page 13](#) for decal options

1264 VALVES

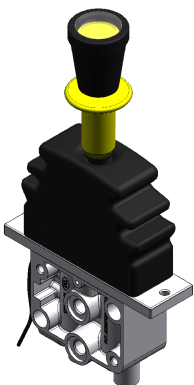

VALVE, LOCK IN NEUTRAL, LIT KNOB	D14-1264-99-01
VALVE, LOCKS IN 2 POSITIONS, LIT KNOB	D14-1264-99-02
VALVE, LOCKS IN 3 POSITIONS, LIT KNOB	D14-1264-99-03

PNEUMATIC CONTROL VALVES

DECAL CHOICES

Used with our 1221, 1224, 1261 and 1264 style valves

Our decals can show a number of functions in various bankable valves and can be customized to your application

Mounted under our **removable magnifying cap (MAGCAP)** to ensure they do not wear or get damaged

Below is a chart of the stock decals we offer following the simple part number scheme of **a number and letter**

For example: PLOW DOWN/UP is part number: **D39-DECAL1A**

	A	B	C	D	E	F
1						
2						
3						
4						
5						
6						
7						
8						
9						

Custom Decals

Have a specific application and don't see it?

Let us design it for you!

Low minimums on prototype designs

Same great benefits of our DEL branded Decals but with:

- CUSTOM FUNCTIONS
- COMPANY LOGOS
- CUSTOM COLORS



PNEUMATIC CONTROL VALVES

1229 VALVES

Stackable feathering valves using one common inlet and exhaust port with one standard bolt length similar to our **1221** valves. However, the **1229** valve series can operate **two functions in one!** The main use of this valve is to operate the **PTO and hoist functions.**

FEATURES:

- 0-120 PSI proportional control
- Has a raised **red** PTO button
- Tamper resistant screw in the **red** PTO button so that the PTO stroke cannot be adjusted
- All 1229 valves **feather** in both directions

OPTIONS:

- Valve spacer to accept various straight-handle configurations
 - See [page 10](#) for valve spacer
- Pressure switch that converts an air signal into an electrical signal

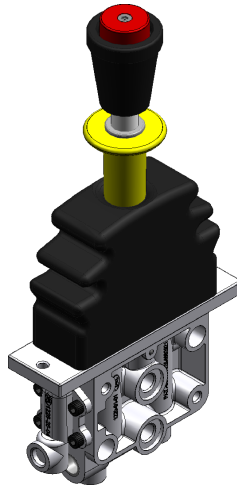

PTO/HOIST VALVE, RAISED BUTTON	D14-1229-99-21
PTO/HOIST VALVE, PTO DISENGAGEMENT	D14-1229-99-02
PTO/HOIST VALVE, DOUBLE DETENT	D14-1229-99-03
PTO/HOIST VALVE, SINGLE DETENT	D14-1229-99-04
PTO/HOIST VALVE, PTO DISENGAGEMENT, SINGLE DETENT	D14-1229-99-05
PTO/HOIST VALVE WITH PRESSURE SWITCH	D14-1229-99-06

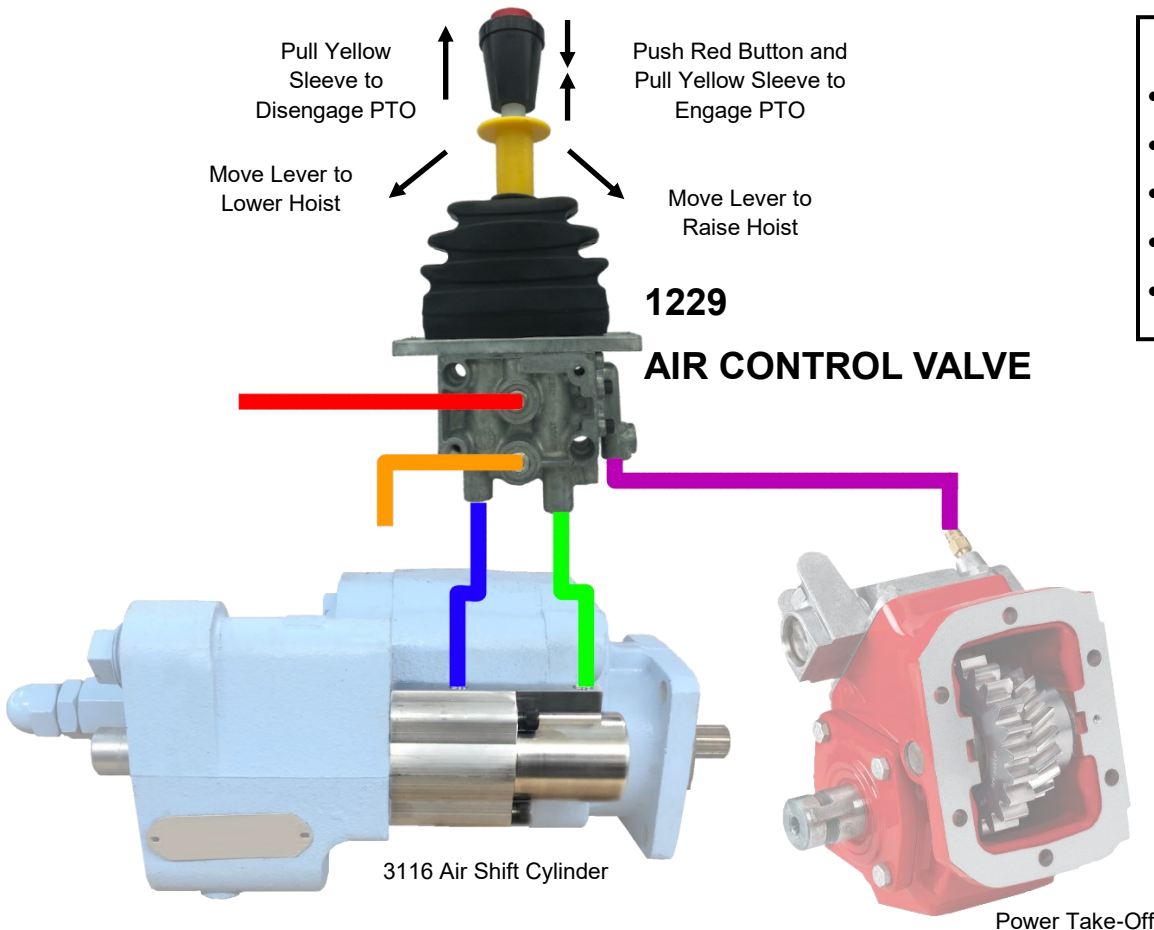

Diagram Key:

- **Purple:** Auxiliary/PTO Port
- **Blue:** Work Port A
- **Green:** Work Port B
- **Red:** Supply
- **Orange:** Exhaust

PNEUMATIC CONTROL VALVES

1229 ACCESSORIES

1229 REPAIR KITS

1229 Minor Repair Kit D02-DAV1229MNRE

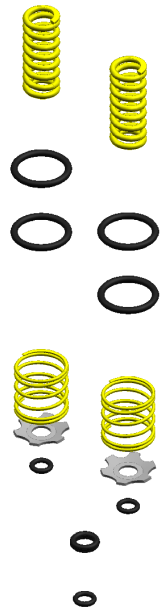

Minor Repair Kit

- Includes O-rings and springs
- **DOES NOT** include pistons or center poppet

1229 Major Repair Kit D02-DAV1229MJRE

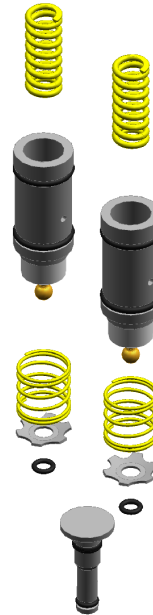

Major Repair Kit

- Includes O-rings, springs, pistons, and center poppet

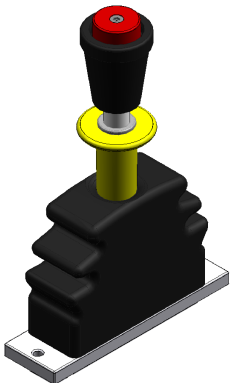

1229 UPPER HANDLE

D14-1229-99-21 UPPER HANDLE ASSEMBLY
D24-1229-9S-32

See console control
[page 21](#) for more
custom fit applications

1229 BRACKET

1229 VALVE BRACKET
D19-DMP1229BRK

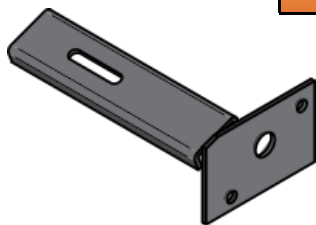

Our **1229 bracket** can also be used for the following:

- 1221, 1224, 1261, and 1264 single valve series

PNEUMATIC CONTROL JOYSTICKS

Feathering joysticks mainly used for front end loaders, roll-off vehicles, municipal snowplow trucks and more.

JOYSTICK PLATE DIAGRAM

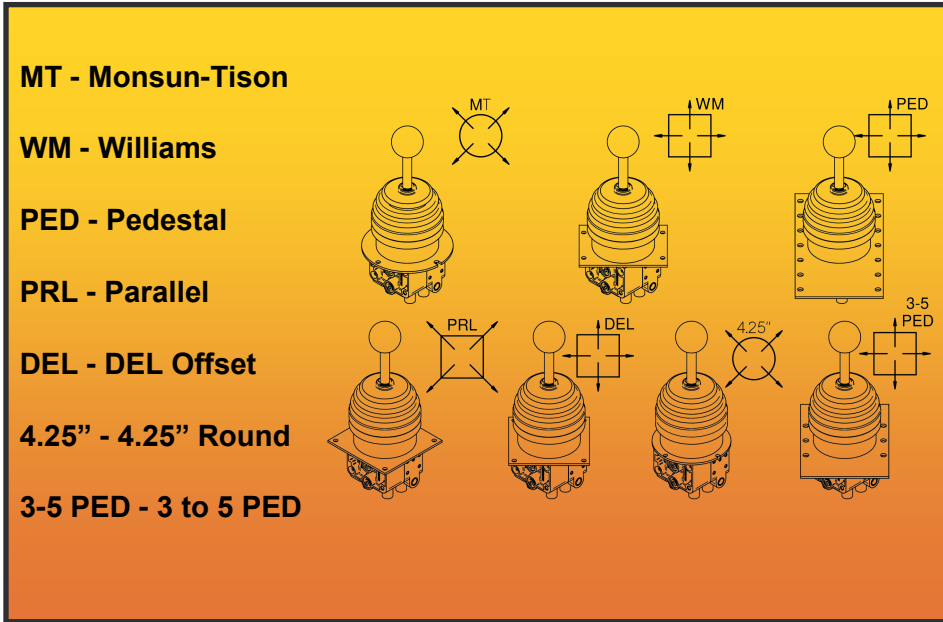

FEATURES:

- 0-120 PSI proportional control
- Compact assembly of two 1221 valves to allow simultaneous operation of various functions with one lever
- 360° articulation

OPTIONS:

- Various mounting plates for aftermarket and OEM applications
- Lit knob
- Electric control handle grip
- Detent in one position for float function
- Push insert cartridge (PIC) fittings
- Directional gate that prevents 360° rotation for more precise control
- Heavy duty return springs

PLATE	JOYSTICK CONTROL ORIENTATION
MT	Corner to Corner
WM	Up, Down, Left, Right
PED	Up, Down, Left, Right
<i>PED plate fits our 7 position pedestal top</i>	
PRL	Corner to Corner
DEL	Up, Down, Left, Right
4.25"	Corner to Corner
3-5 PED	Up, Down, Left, Right
<i>3-5 PED plate fits our 3 or 5 position pedestal tops</i>	
<i>See page 22 for all pedestal options</i>	

Any joystick series and plate style can be combined to fit your application

See next page for our standard joystick part numbers



1226 Series



1226 Gated Series



1226 Push Insert Cartridge (PIC) Fittings Series



1227 Series
*Detented



1285 Series
*Detented
*Lit Knob



1286 Series
*Momentary 3 Pos. Switch

PNEUMATIC CONTROL JOYSTICKS

PART NUMBER	DESCRIPTION
1226 Series	
D45-1226-99-01	MT Plate
D45-1226-99-02	Williams Plate
D45-1226-99-03	Pedestal Plate
D45-1226-99-04	Parallel Plate
D45-1226-99-05	DEL Offset Plate
D45-1226-99-06	4.25" Round Plate
D45-1226-99-08	3 to 5 PED Plate
Specialty 1226 Series	
D45-1226-99-11	MT Plate, Gated
D45-1226-99-31	MT Plate, PIC fittings
D45-1226-99-32	Williams Plate, PIC fittings
D45-1226-99-34	Parallel Plate, PIC fittings
D45-1226-99-43	Two Dual Joysticks, Pedestal Plate
1227 Series	
D45-1227-99-11	MT Plate, Detented
D45-1227-99-13	Pedestal Plate, Detented
1285 Series	
D45-1285-99-03	Pedestal Plate, Lit Knob, Detented
1286 Series	
D45-1286-99-06	MT Plate, 3-pos., Momentary Grip, HD springs
D45-1286-99-09	Parallel Plate, 3-pos., Momentary Grip, HD springs
D45-1286-99-10	DEL Offset Plate, 3-pos., Momentary Grip, HD springs
D45-1286-99-11	MT Plate, 3-pos., Momentary Grip, HD springs, PIC fittings

Call our office at 716-853-7996 for specialized joystick applications

PNEUMATIC CONTROL JOYSTICKS

JOYSTICK REPAIR KITS

1226 REPAIR KITS

Minor Repair Kits

- Includes O-rings and springs
- **DOES NOT** include pistons

For 1226, 1227, and 1285 series joysticks

Major Repair Kits

- Includes O-rings, springs, and pistons

1226 Minor Repair Kit D02-DAV1226MNRE

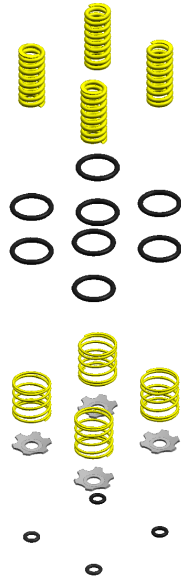

1226 Major Repair Kit D02-DAV1226MJRE



Minor Repair Kit

- Includes O-rings and HD springs
- **DOES NOT** include pistons

1286 REPAIR KITS

1286 Minor Repair Kit D02-DAV1226HDMNRE

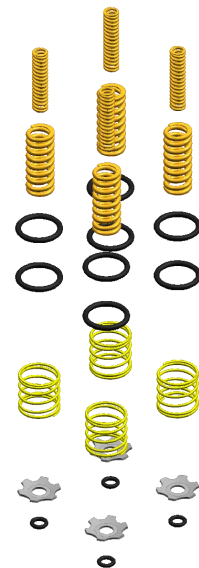

1286 Major Repair Kit D02-DAV1226HDMJRE

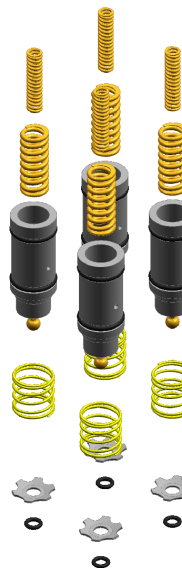

Major Repair Kit

- Includes O-rings, HD springs, and pistons

PNEUMATIC CONTROL SHIFTERS

DUMP PUMP ACTUATORS

DEL Hydraulics manufactures direct mount air shift cylinders for various hydraulic dump pumps. They allow proportional control for lowering dump bodies, end dump trailers, etc. that utilize pneumatic controls. Benefits include less installation time and lower overall maintenance costs.

PART NUMBER	APPLICATION	SPOOL THREAD SIZE
D15-3010-99-02	Parker G101/102, Non-Detent	1/4-20
D15-3035-99-01	Permco DMD25	3/8-16
D15-3051-99-01	Permco DMD400 (Direct)	W/O Thread
	Permco DMR400 (Remote)	W/O Thread
D15-3116-99-03	Muncie E/EH, C101, C102	W/O Thread
	Parker C101/102	W/O Thread
	Permco DM640	W/O Thread

FEATURES:

- Die-cast Zinc Alloy or Aluminum body
- Non-Binding
- Compact size
- Proportional control
- Preassembled for quick and simple installation
- No exposed parts

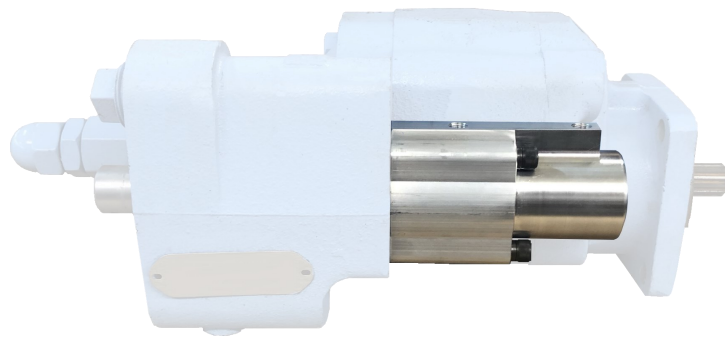

DEL D15-3116-99-03 installed on a dump pump

PRE-ASSEMBLED! ULTRA COMPACT! SIMPLE INSTALLATION!

All Moving Parts
TOTALLY ENCLOSED!

FEATHERING
FEATHERING
FEATHERING
FEATHERING

Our air shift cylinders fit various dump pumps and hydraulic valves including: PARKER, REXROTH, CROSS, VALVOIL, PERMCO, MUNCIE, PRINCE, SALAMI and more

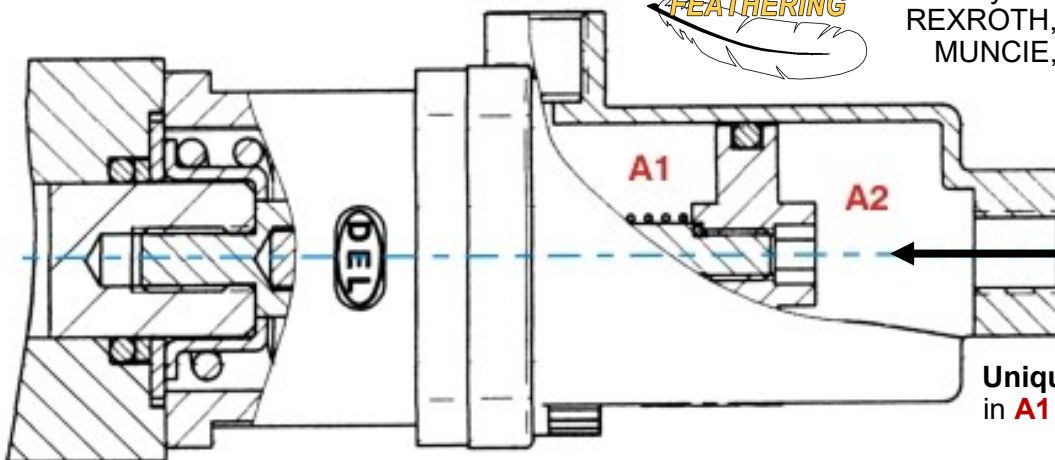

Simple installation!
Easy Access to spool thread - Just tighten with hex wrench

Unique Design creates balanced areas in **A1** and **A2** for consistent proportional control in both directions

Self-alignment feature prevents binding & jamming of the hydraulic spool

DON'T GET CAUGHT IN A BIND!

PNEUMATIC CONTROL SHIFTERS

HYDRAULIC VALVE ACTUATORS

PARKER SERIES			PRINCE SERIES		
PART NUMBER	APPLICATION	SPOOL THREAD SIZE	PART NUMBER	APPLICATION	SPOOL THREAD SIZE
ASC-A20	A20	3/8-16	D16-3024-99-03	5100 Monoblock	1/4-20
ASC-V20	V20	5/16-18	SALAMI SERIES		
D16-3015-99-03	V42	3/8-16			
D16-3017-99-03	25P	3/8-16	PART NUMBER	APPLICATION	SPOOL THREAD SIZE
3019-99-03	A35	3/8-16	D16-3062-99-03	VD8A	M7x1
D16-3027-99-03	V40	1/2-20	CROSS SERIES		
D16-3034-99-03	S-100	3/8-16			
D16-3050-99-01	K-18	1/4-20	PART NUMBER	APPLICATION	SPOOL THREAD SIZE
			D16-3026-99-03	BA	1/4-20

HEIL SERIES			BLB SERIES		
PART NUMBER	APPLICATION	SPOOL THREAD SIZE	PART NUMBER	APPLICATION	SPOOL THREAD SIZE
D16-3043-99-01	031-6131-HPT	3/8-24	D16-3075-99-03	150 Series	M8

HUSCO SERIES			SAUER DANFOSS SERIES		
PART NUMBER	APPLICATION	SPOOL THREAD SIZE	PART NUMBER	APPLICATION	SPOOL THREAD SIZE
D16-3038-99-03	5000 Series	5/16-24 & 3/8-24	D16-3082-99-04	PVG32-EL-SL	M8x1.25
D16-3039-99-03	6000 Series	M8x1.25	D16-3083-99-06	PVG32-MAN	M8x1.25

WILLIAMS SERIES			BUCHER SERIES		
PART NUMBER	APPLICATION	SPOOL THREAD SIZE	PART NUMBER	APPLICATION	SPOOL THREAD SIZE
D16-3025-99-03	08 Series	1/4-20	3087-99-03	HDS-15	M8x1.25

Need Help Selecting an Air Shifter?

Please contact our office at 716-853-7996 with the below information to get started

1. **What is the application?**
2. **Measure the shifter mounting bolt pattern on the hydraulic valve from center to center.**
See Figure 1 - A1/A2 or B1 depending on style
3. **Provide spool thread size.**
See Figure 2 - C1 - Note: Can be threadless/pin
4. **Provide any part numbers on the hydraulic valve.**

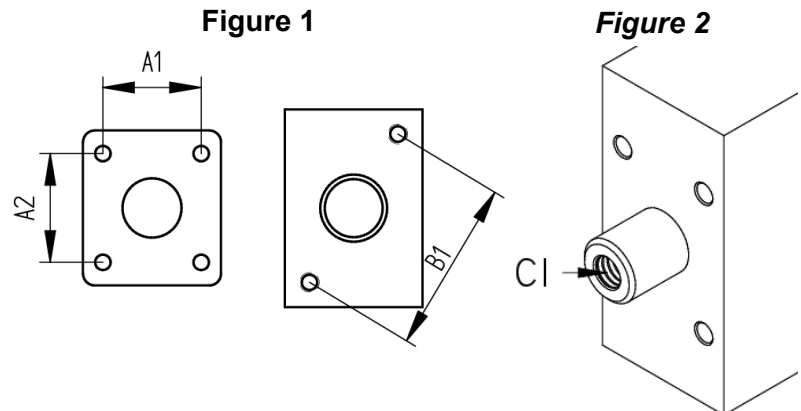

CONTROL CONSOLES

Guide to Ordering

- Know which DEL air control valve is to be installed in the console
- Height of console required
- For example: a 1202 5" console is part number CONKIT-1202A



CONKIT-1202A



CONKIT-1203B



CONKIT-1221B

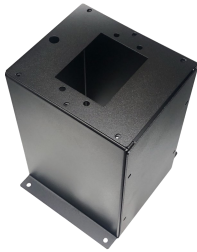

CONKIT1221X2B



CONKIT1221X3C



CONKIT1221X4B



CONKIT1221X5C



CONKIT1295-01B

PART NUMBER	CONSOLE HEIGHT			
	5"	10"	14"	16"
CONKIT-1202	A	B	-	-
CONKIT-1203	A	B	-	-
CONKIT-1221 Can be used for: 1221, 1224, 1229, 1261 & 1264 series	-	B	C	D
CONKIT1221X2	-	B	C	-
CONKIT1221X3	-	B	C	-
CONKIT1221X4	-	B	C	-
CONKIT1221X5	-	B	C	-
CONKIT1295-01 Top Plate comes with 1295 Valve	A	B	-	-
TR-29-1016 Adjustable height from 10" -16" Can be used for: 1221, 1224, 1229, 1261 & 1264 series	-	ADJ.	ADJ.	ADJ.
TR-21-1016 Adjustable height from 10" -16" Can be used for: 2-Bank & 3-Bank series	-	ADJ.	ADJ.	ADJ.

FEATURES: 14 Gauge Powder Coated Heavy Duty Steel Valve & PTO Light Cutout
Includes: Main Housing, Side Panels, and Top Plate
See [Page 23](#) for DEL Red Warning Light

More Custom Control Kits Available to Fit Your Specific Applications - See [Page 24](#)
Call us today (716) 853-7996

***Console hardware is a separate line item our sales team will add at the time of order**

CONTROL PEDESTALS

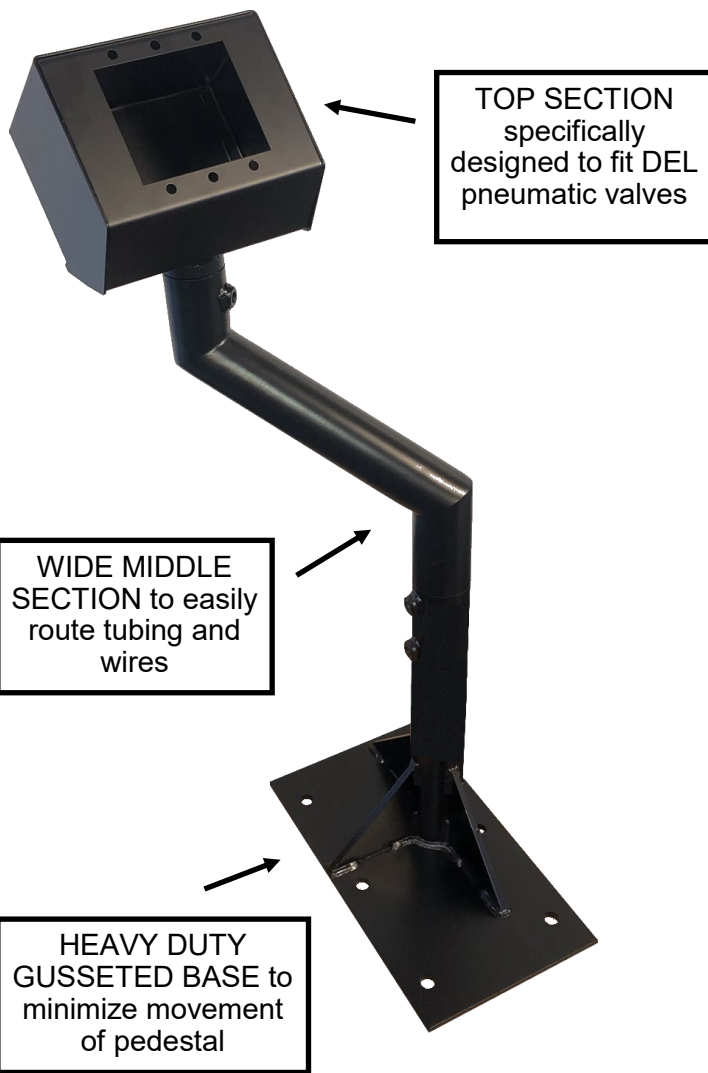

Once the base is installed to the floor, the middle, and top sections can be rotated to either the driver or the passenger side by unlocking the lock knobs then tightening again.

FEATURES:

- Removable top and middle sections for easy access
- Simple installation saves on overall costs
- Accepts round tubing through the base, middle, and top
- Powder coated to blend into the cab

OPTIONS:

- Pedestal tops can fit multiple valves including spacers for a wide range of applications
- Various pedestal base heights available

PEDESTAL TOPS

2 POS. PEDESTAL TOP	D20-DSNP2T
3 POS. PEDESTAL TOP	D20-DSNP3T
4 POS. PEDESTAL TOP	D20-DSNP4T
5 POS. PEDESTAL TOP	D20-DSNP5T
6 POS. PEDESTAL TOP	D20-DSNP6T
7 POS. PEDESTAL TOP	D20-DSNP7T
9 POS. PEDESTAL TOP	D20-DSNP9T
11 POS. PEDESTAL TOP	D20-DSNP11T
13 POS. PEDESTAL TOP	D20-DSNP13T

PEDESTAL MIDDLE

PEDESTAL MIDDLE SECTION	D20-DSNPM
-------------------------	-----------

PEDESTAL BASES

6" GUSSETED PEDESTAL BASE	D20-DSNPBG6
8" GUSSETED PEDESTAL BASE	D20-DSNPBG8
12" GUSSETED PEDESTAL BASE	D20-DSNPBG12
16" GUSSETED PEDESTAL BASE	D20-DSNPBG16

PEDESTAL HARDWARE

PEDESTAL LOCK KNOB	3035BF
--------------------	--------

ACCESSORIES

DEL Hydraulics offers a variety of accessories to complete your pneumatic system. These can be added on at the same time as the air controls or at a later date.

TUBING & FITTING KITS

1/4" TUBING/FITTING KIT - **COLOR: CLEAR**
D17-DAK250FK

1/4" DOT APPROVED TUBING/FITTING KIT
COLOR: BLACK
D17-DAKFLDKITDOT

5/32" TUBING/FITTING KIT
8 COLOR OPTIONS:
BLACK, CLEAR, RED, ORANGE, YELLOW,
GREEN, BLUE, AND GRAY
D17-DAK532FK

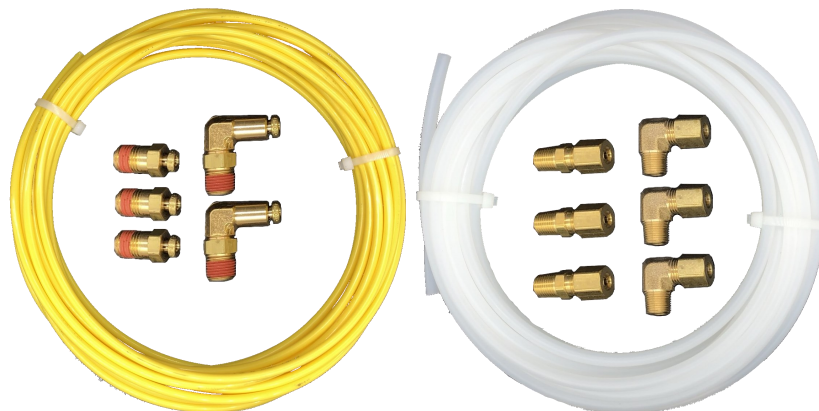

5/32" Tubing and Fitting Kit

Eight colors available

1/4" Tubing and Fitting Kit

Non-DOT shown

OILER LUBRICATOR & REGULATOR

FILTER/LUBRICATOR & REGULATOR
D27-F14G11B-RWE

FEATURES:

- Compact all in one filter/lubricator and regulator with 1/8" NPT ports
- Bracket incorporated for simple installation
- Includes air gauge

- Each tubing/fitting kit is supplied with 30' of tubing
- All fittings are **1/8" male NPT**
- **D17-DAK250FK** includes:
 - 3x straight 1/4" compression fittings
 - 3x 90° 1/4" compression fittings (non-swivel)
- **D17-DAKFLDKITDOT** has the same style fittings as **D17-DAK250FK** but are **DOT** approved
- **D17-DAK532FK** includes:
 - 3x straight 5/32" PTC fittings
 - 2x 90° 5/32" PTC fittings (swivel)

FLASHING WARNING LIGHT

RED LED WARNING LIGHT - 14V
D22-DAVLLIGHTS

WARNING BUZZER

3/4" PANEL MOUNTED WARNING BUZZER - 14V
D02-DAVBZZER

AIR SHUTTLE VALVE

AIR SHUTTLE VALVE
D27-S125

FEATURES:

- Dual inputs with check valves to prevent cross flow between inputs
- Single output - operate a function from two different controls: inside and outside the cab
- 1/8" NPT Female ports

Pre-assembled Control Packages



Pre-assembled Control & Consoles

Our control and console packages are delivered fully assembled for immediate integration.
Installation is as easy as 1, 2, 3!

1. Mount the console in the truck
2. Connect the supplied tubing and wiring
3. Check the system for desired functionality

13" CONSOLE - HOIST, PTO, AND HIGH PRESSURE CONTROL, PRE PLUMBED AND WIRED, WARNING LIGHT AND BUZZER

DVC-1295-HP-13

13" CONSOLE - HOIST AND HIGH PRESSURE CONTROL, PRE PLUMBED AND WIRED, WARNING LIGHT AND BUZZER

DVC-2202-HP-13

13" CONSOLE - HOIST AND TAILGATE CONTROL, PRE PLUMBED AND WIRED, WARNING LIGHT AND BUZZER

DVC-2202-TG-13

Custom Assemblies

Expanding on our pre-assembled control and console offerings, DEL provides made-to-order custom console and control assemblies. Let DEL partner with you to create a control solution that aligns seamlessly with your operational requirements.

Key Benefits:

- Designed precisely for your unique setup
- Enhance brand visibility with specific branding elements
- Seamless integration means fewer adjustments and quicker deployment

Interested? Contact us today to get started!
716-853-7996 - sales@delhydraulics.com

**Minimum order quantity required*



BACK TO T.O.C.

DEL SAFETY SYSTEMS

DEL INTERLOCK SYSTEM FOR PTO APPLICATIONS

PREVENTS UNINTENTIONAL USAGE OF YOUR TRUCKS PTO SYSTEM

The risks of leaving a PTO engaged range from PTO burnout to overhead collisions. Tying into the trucks 4-way flasher light circuit, the PTO can only engage when the flashers are running. Our **patented*** interlock system can be retrofitted into existing setups or installed by an OEM / upfitter



Key Features:

- Prevents early PTO failure due to burnout
- Reduce the risk of a costly and potentially fatal bridge strike
- Audible and visual signal to operator via the trucks flasher system
- Easy integration into existing systems
- Quick connect electrical terminals
- 1/4" Compression fittings for easy pneumatic connections

*Patent #11,813,977

DIS FOR AIR SHIFT PTO

DIS-PTO-A

DIS FOR ELECTRIC SHIFT PTO

DIS-PTO-E

DEL INTERLOCK SYSTEM FOR OTHER APPLICATIONS

DIS WITH LIFTGATE DECAL

D03-DIS-SP

DIS WITH NO DECAL

D03-DIS

FEATURES:

- Can be used in hydraulic circuits being operated with an exterior switch such as small hoists or tailgate liftgates
- Turning the hazard lights off shuts the application's electric motor off preventing accidents and warning any bystanders



DEL ACK SYSTEM

Interested in deploying DEL pneumatic controls but the application doesn't have air brakes or an air compressor?

The DEL ACK system offers a way to introduce air to operate our controls in trucks without air.

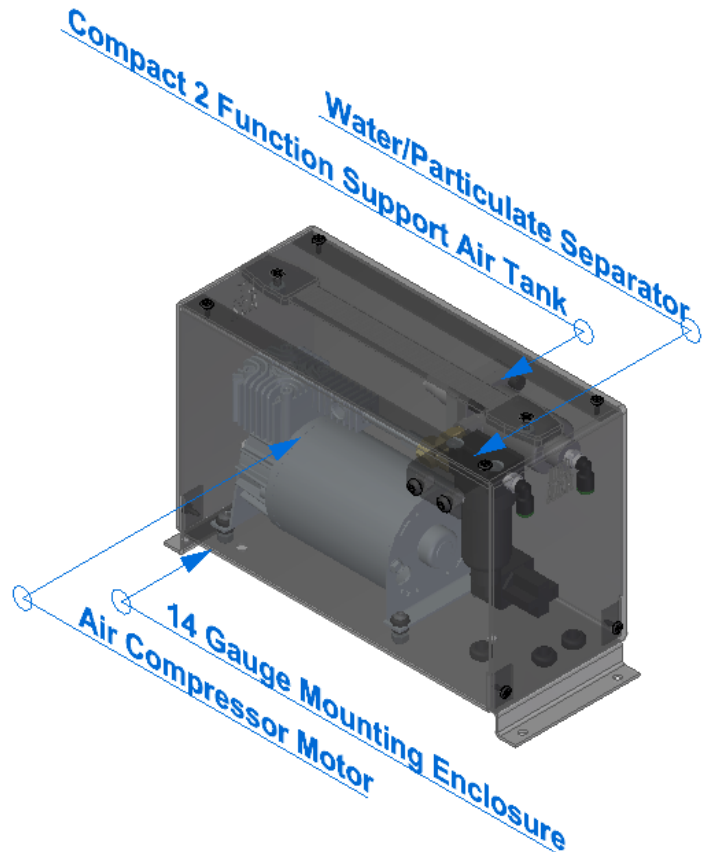

Kit Includes:

- **Oil-less operated Air Compressor/Motor**
 - **Features:**
 - Heavy duty, permanently lubricated, low upkeep, thermal overload protected motor
 - Vibration isolated mounting feet
 - Remote Air Inlet
 - **Ratings:**
 - Voltage: 12 VDC
 - Max. Amperage: 18 Amps
 - Max Duty Cycle @ 72°F & 100 PSI: 25%
- **Compact and Efficient Air Tank for 2 function support**
- **Water and Particulate Separator with Auto Drain**
- **14 GA Mounting Enclosure:** Black Textured Powder Coated finish
 - Dimensions: 12" x 4.6" x 7.5" (LxWxH)
- Reinforced strap handle for ease of installation and relocation

Use our ACK system with our *feathering* air controls for a complete package!

NOTES

Lined area for taking notes.

NOTES

BUILDING *FOR THE* **FUTURE**

**CONTROL SOLUTIONS
FOR MOBILE APPLICATIONS**



**DEL Products are proudly manufactured in
Buffalo, New York!**

**DEL Hydraulics, INC.
TEL: 716-853-7996 EMAIL: sales@delhydraulics.com**